

## **General Instructions**

1. Check material received against the packing list. First, check the number of packages received and then check the contents of each package.
2. Check the material received for damage. If damage has occurred, secure a “damage notation” from the carrier
3. Identify each part as it is unpacked and put like parts together as close as possible to the working area where they are to be assembled.
4. Be careful to use the correct hardware as specified in the assembly instructions.

## **CAUTION**

In the interest of safety, all lockers must be securely anchored to the floor and/or wall. For safety, handle all components carefully and wear work gloves when assembling lockers. Install all units plumb and tighten all hardware securely. Retain instruction for future reference.



866-566-0500

[info@Hallowell-List.com](mailto:info@Hallowell-List.com)

[www.Hallowell-List.com](http://www.Hallowell-List.com)

FORT KNOX MODULAR UTILITY STORAGE & WORKBENCH SYSTEM  
UNIT DIMENSIONS

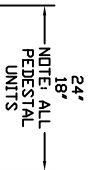
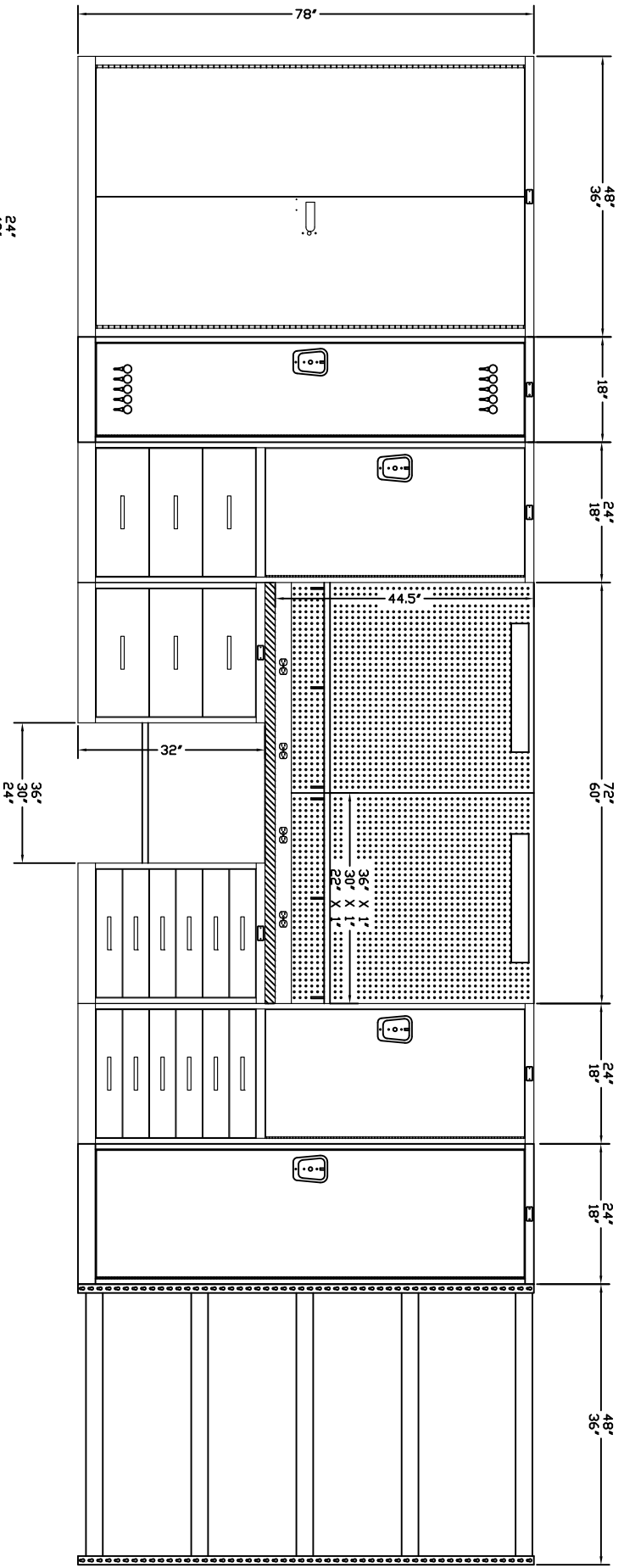

- NOTE:
1. All units are 24" deep.
  2. Side Pegboards are 22".

# (OPTIONAL) FORT KNOX CABINET DRAWER KIT INSTALLATION

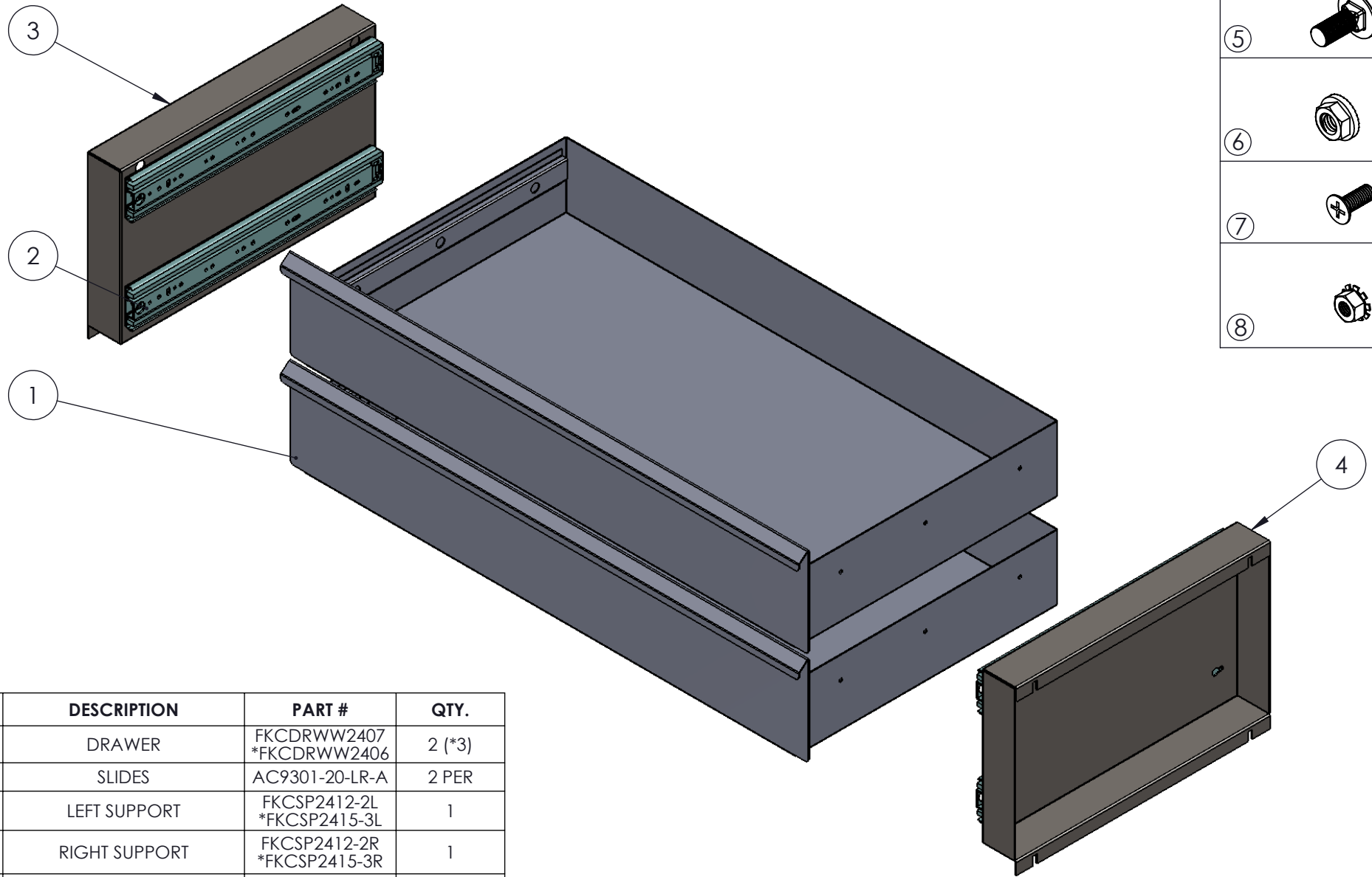

ITEM NO.	DESCRIPTION	PART #	QTY.
1	DRAWER	FKCDRWW2407 *FKCDRWW2406	2 (*3)
2	SLIDES	AC9301-20-LR-A	2 PER
3	LEFT SUPPORT	FKCSP2412-2L *FKCSP2415-3L	1
4	RIGHT SUPPORT	FKCSP2412-2R *FKCSP2415-3R	1
5	5/16-18 X .75 RND HD	CB100	4
6	5/16-18 HEX FLANGE NUT	N105	4
7	M6X1 16MM PHILLIPS	MS200M	6 PER
8	M6X1 10MM KEPS NUT	N500M	6 PER

**LEGEND:**  
WW: WIDTH

\*ITEMS ONLY FOR 3 DRAWER UNIT

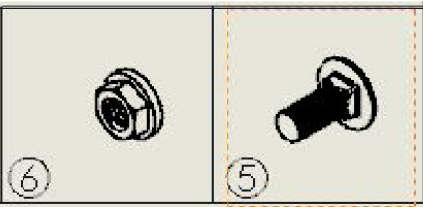

STEP 1

- 1) Assemble nuts and bolts loosely (6 & 5).
- 2) Insert nut and bolt to the location where the drawers are going to be located.
- 3) 3 holes in between top and bottom bolt.  
\* 4 holes in between top and bottom bolt for 3 drawer kit.

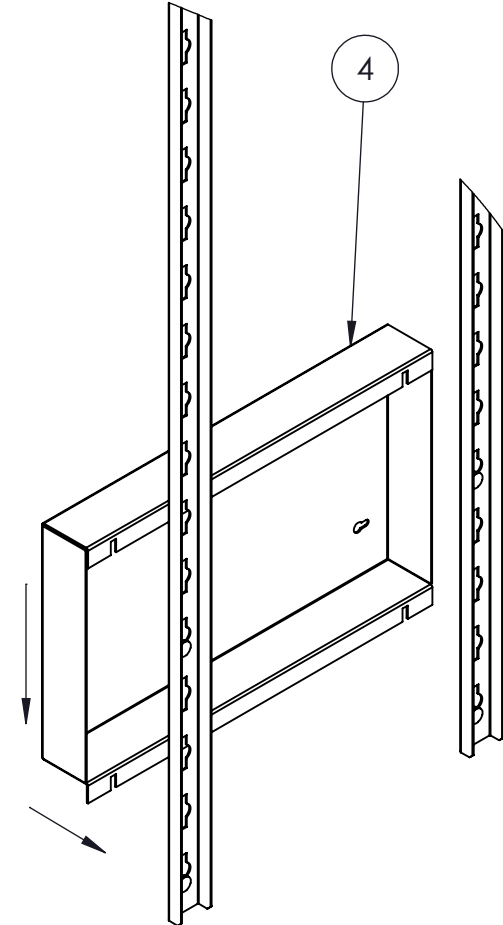
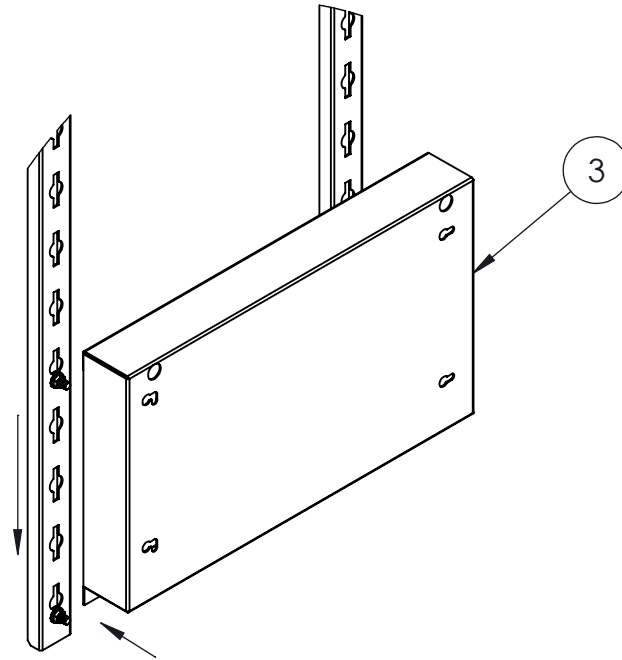
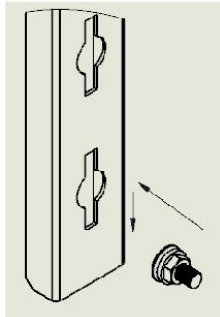

- 4) Place the drawer support (3 & 4) above the bolts and line up the notches on the support with the bolts.
- 5) Slide the support down so that the bolts go into the notches.
- 6) Make sure the flange of the support is in between the flange nut and the shelf support.
- 7) Tighten the nuts and bolts with a 3/4" socket head.  
NOTE: Use an extension head to tighten the top nuts. Use the hole at the top of the drawer support to introduce the 3/4" socket head and extension to tighten the nuts.

STEP 2

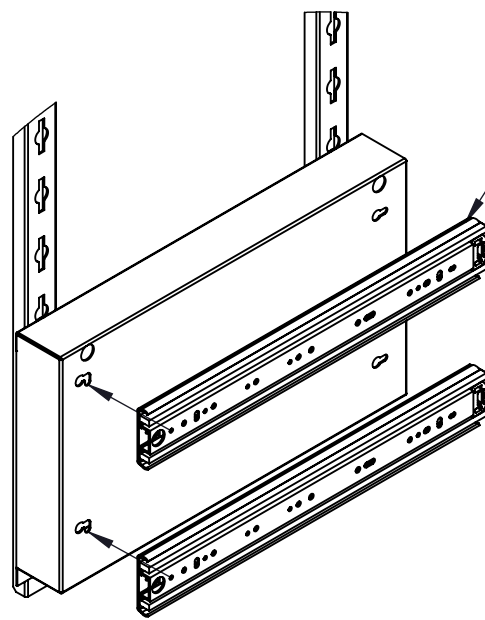

Make sure slides are leveled before installing the drawers.

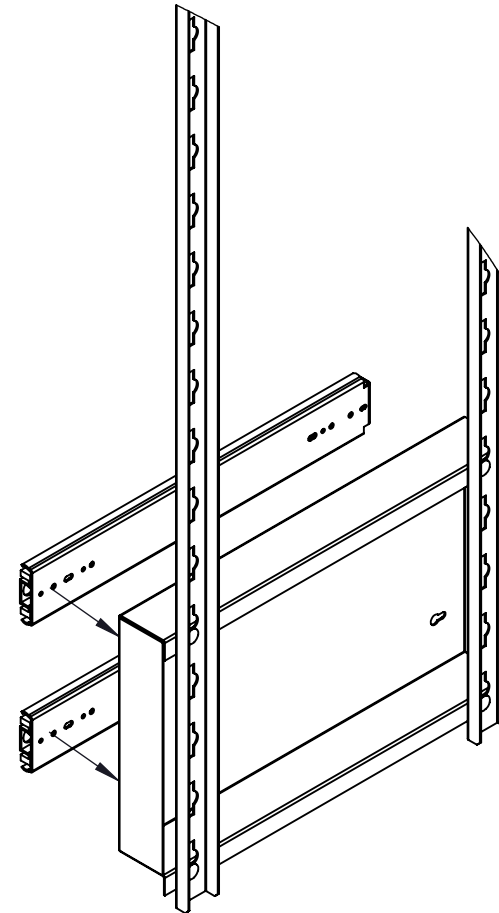

1) Line up the rivet head on the slides with the holes on the support and insert the slide. Make sure the slide opens towards the front of the unit.



2) Push the slide back.

3) Push the front of the slide down.

NOTE: Use a rubber mallet or wood piece if necessary for steps 2 and 3.

## (OPTIONAL) FORT KNOX CABINET DRAWER KIT INSTALLATION

Hallowell®

### STEP 3

NOTE: USE TWO PEOPLE FOR THE FINAL INSTALLATION OF THE DRAWERS!

- 1) Open the slides in order to begin installation.
- 2) Position either of the drawers in between the slides.
- 3) Insert the two middle bolts (7) in order to keep the drawer in place. Flat head of bolt must be towards the outside of the drawer. Finger tighten the nut (8) onto it.
- 4) Insert front and back bolts and finger tighten the nuts onto them.
- 5) Repeat steps 1-4 for the remaining drawers.
- 6) Make sure all drawers are parallel to one another and tighten all bolts completely.

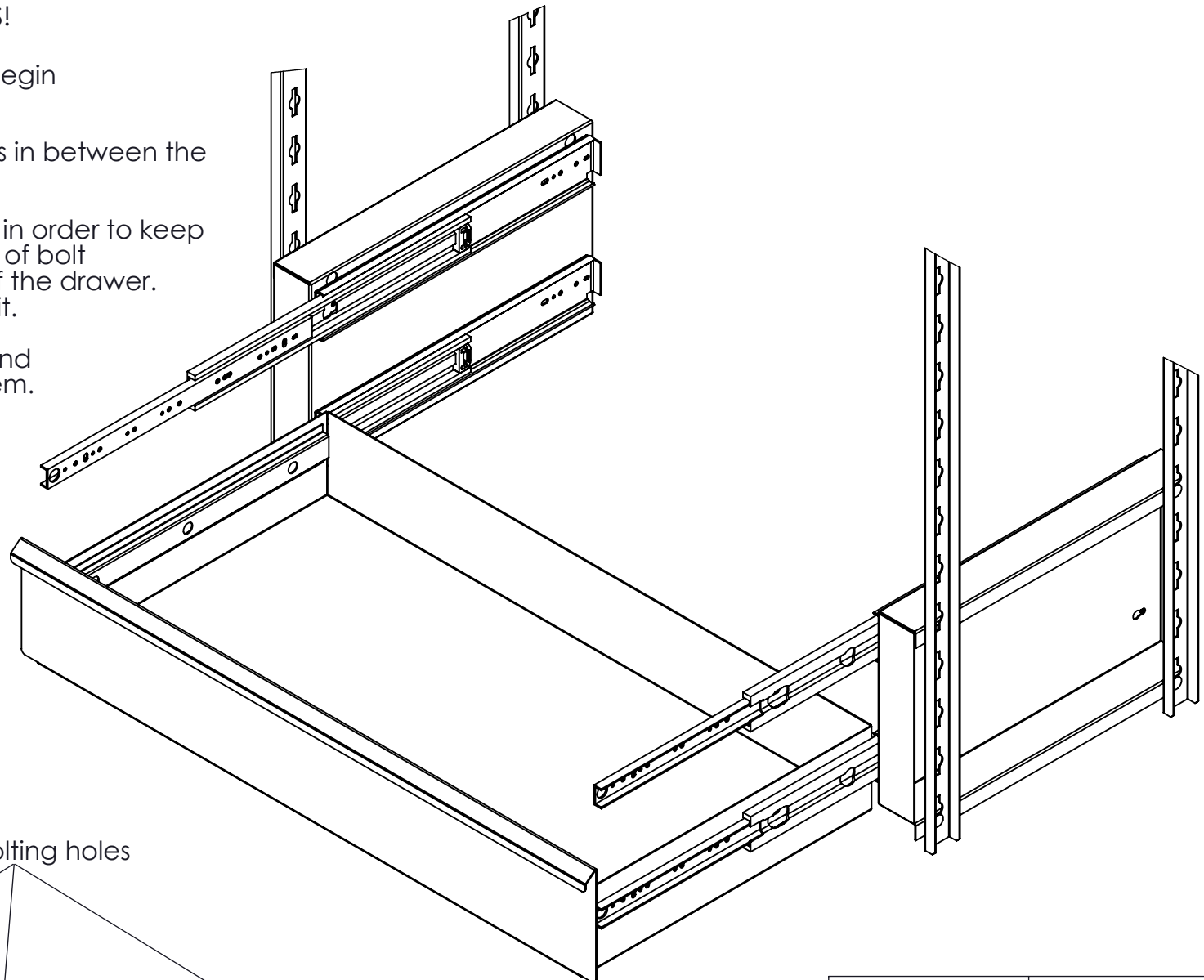

Drawer bolting holes

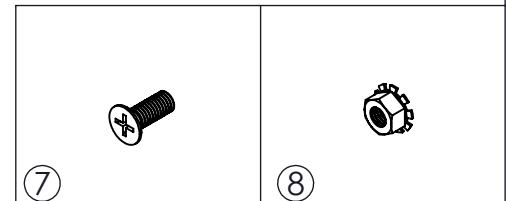
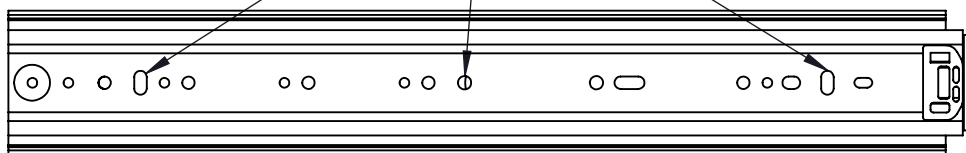

**CABINET TOP DRILLING**

Regardless of the type of Top you will be attaching to the cabinet, remove sufficient top drawers from the cabinet for proper installation.



**WOOD TOP ATTACHMENT**

1. Set Wood Top on the Pedestal Units and align the corners.
2. With a permanent black marker, mark through the holes in the top of cabinet to mark to Wood Top.
3. Remove the Wood Top and use the markings as the drilling pattern. Drill (4) 13/16" diameter holes by 1" deep.
4. Attach with Wood Top with 1/4" x 1" lag screws and 1/4" flat washers.
5. Replace drawers into location and check for proper operation.

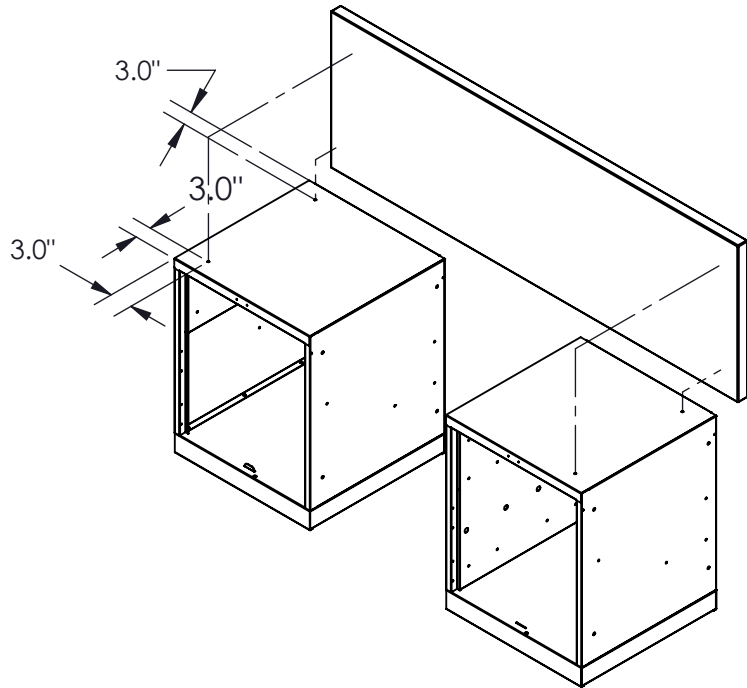

**STEEL TOP ATTACHMENT**

1. Drill (2) 9/32" diameter holes on each pedestal unit using the template below.
2. Set the Steel Top on the unit and align the holes.
3. Bolt together using 1/4-20x1 bolts and 1/4-20 nuts.
4. Replace drawers into location and check for proper operation.

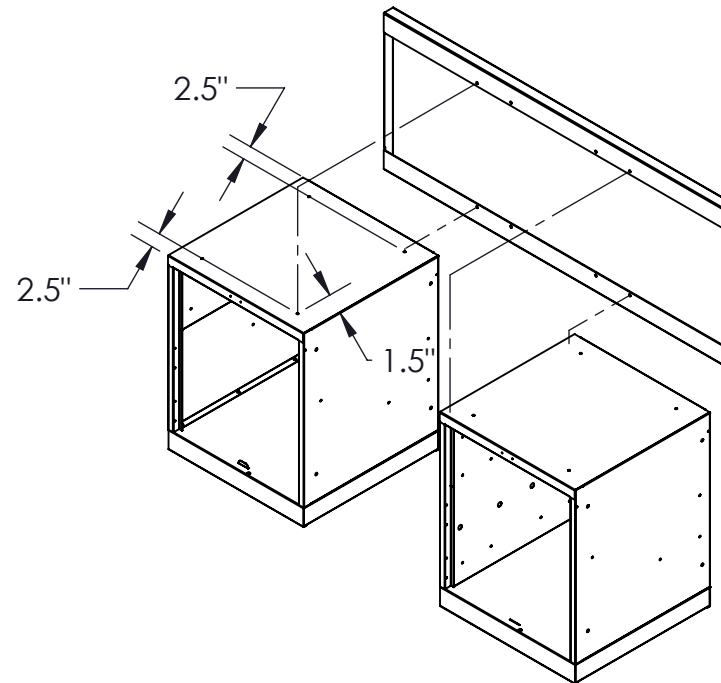

# (OPTIONAL) FORT KNOX PEGBOARD INSTALLATION



## SIDE PEGBOARD

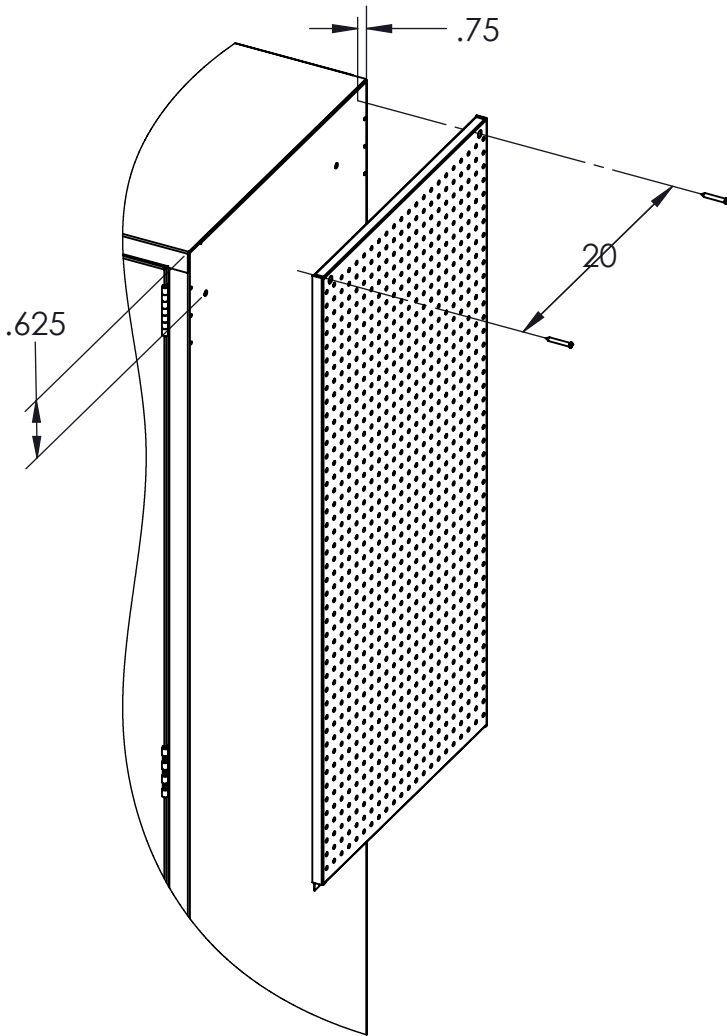

1. Drill (4) 1/8" diameter holes in the locations shown above.
2. Align holes on Pegboard with the one on the locker and use #8-1/2 self tapping tek screw.

## WALL PEGBOARD

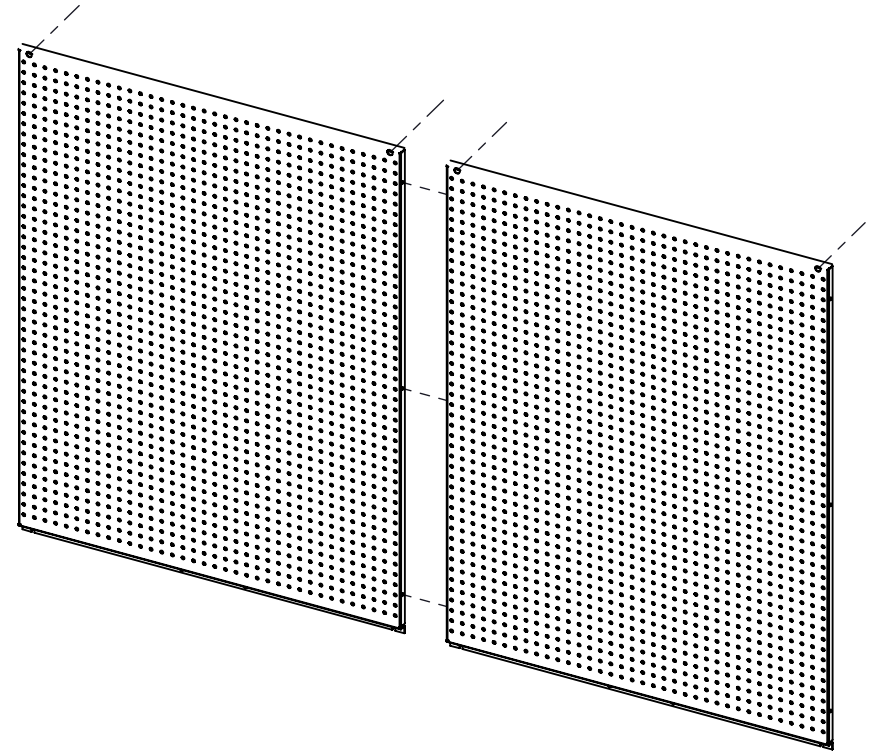

1. Bolt both Wall Pegboards together use the (3) holes on the side flanges.
2. Place Pegboards against wall in the location desired.
3. Mark with a pencil the location of the holes where the Pegboards are held.
4. Drill holes in the locations marked in accordance to the wall where the Pegboard is to be mounted.  
I.E : Dry wall, concrete, or wood.



# FORT KNOX SHELVING

RIVETWELL BY HALLOWELL

## ASSEMBLY INSTRUCTIONS

1. Start by putting side frame assemblies together by inserting front to back beams (part ABS/ABH) into post at top and bottom.
2. Once both side frame assemblies are made, take one side frame assembly and insert one left to right angle beam (ABS/ABH) into the bottom of front post and one left to right beam into the bottom of the rear post. This will make the frame stand up by itself. Now insert the opposite end of the same left to right beams (ABS/ABH) into the other frame assembly.
3. Now with the unit standing, insert additional beams required to complete unit.
4. Assemble center supports to angle beams and/or channel beams using (4) 1/4-20 x 1/2 bolts and hex nuts per support.

## NOTES

1. When inserting beams into slots on post, beams must be seated into bottom of slots with a Rubber Mallet.
2. Beams cannot be placed in the level occupied by a splice plate.

## WARNING

RIVETWELL units are intended for use in hand-loaded applications only.

Powered material handling equipment should never be used around RIVETWELL units without HALLOWELL approval.

## COMPONENTS

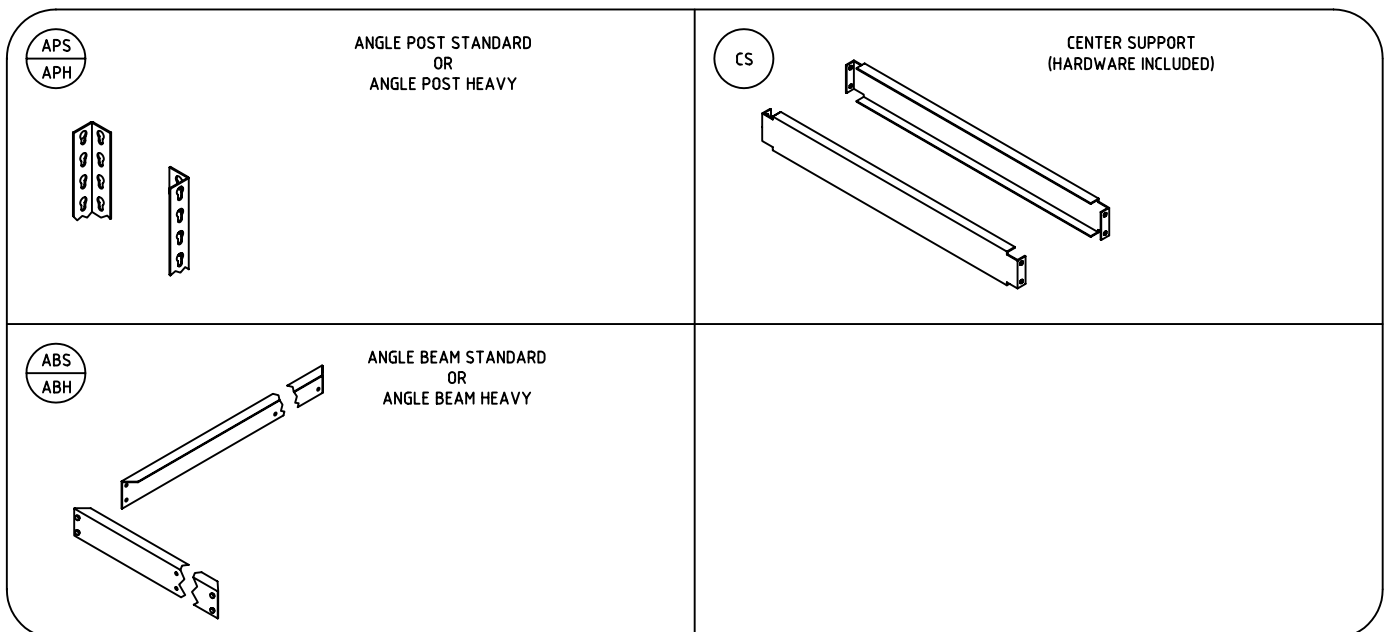

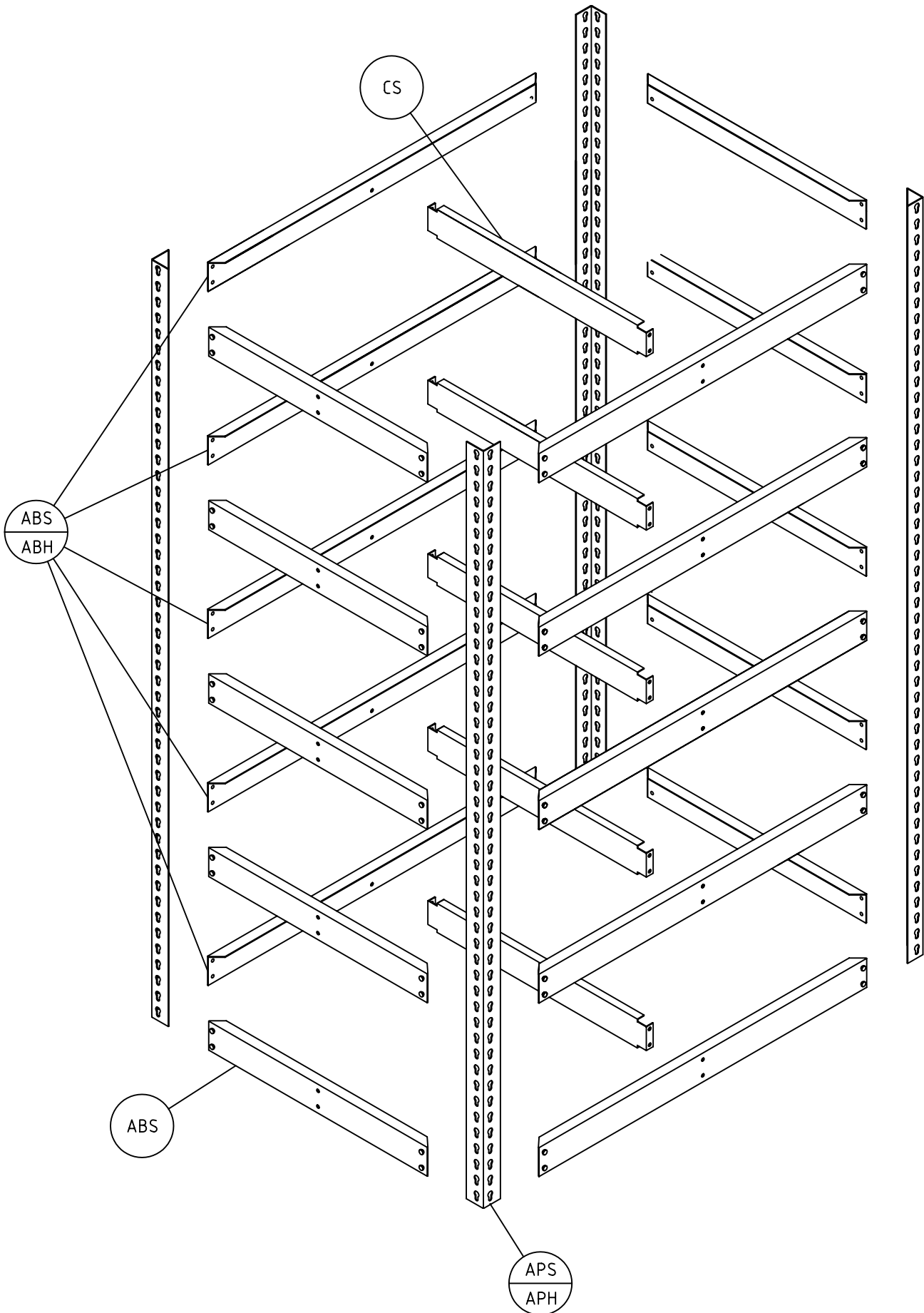



# CAUTION

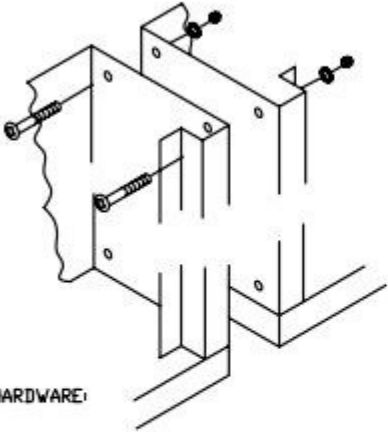
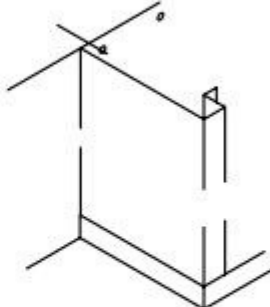

In the interest of safety, all lockers taller than 36" must be securely anchored to the floor and/or wall for safety . Handle all components carefully and wear work-gloves when assembling units. Install all units plumb and tighten all hardware securely . Retain Instructions for future reference.

UNITS END TO END	UNITS TO WALL
 <p>HARDWARE:</p> <ul style="list-style-type: none"> <li>(4) 1/4"-20 X 3/4" PHILLIPS PAN HEAD SCREWS</li> <li>(4) 1/4"-20 HEX NUT</li> <li>(4) 1/4" EXTERNAL TOOTH LOCK WASHER</li> </ul>	<p>DRILL 9/32" DIA. HOLE THRU BACK SHEET OF LOCKER AND INTO WALL APPROX. 2" FROM UPPER CORNER ON EACH SIDE OF UNIT.</p>  <p>HARDWARE:</p> <ul style="list-style-type: none"> <li>(2) ANCHORS BY INSTALLER-RECOMMENDED HILTI ALUMINUM HIT ANCHORS CAT. LND. 5400192</li> <li>1/4" X 2" TAP-CON OR QUICK.</li> </ul>

RECOMMENDED TOOLS
<p>*C* CLAMPS, HAMMER DRILL, VICE GRIPS            SABER SAW, 3/8" ELECTRIC DRILL            3/8" NUT DRIVER, ASSORTED CEDAR SHIMS,            ELECTRIC SCREW GUN W/ADJUSTABLE TORQUE            WONDER BAR, #2 &amp; #3 PHILLIPS BITS            RIVET GUN &amp; 5/16, 3/8 AND 7/16" HEX DRIVES</p>

## WARNING:

Floor anchor must have a minimum pull-out value of 190lbs.

Wall anchor must have a minimum pull-out value of 150 lbs.